

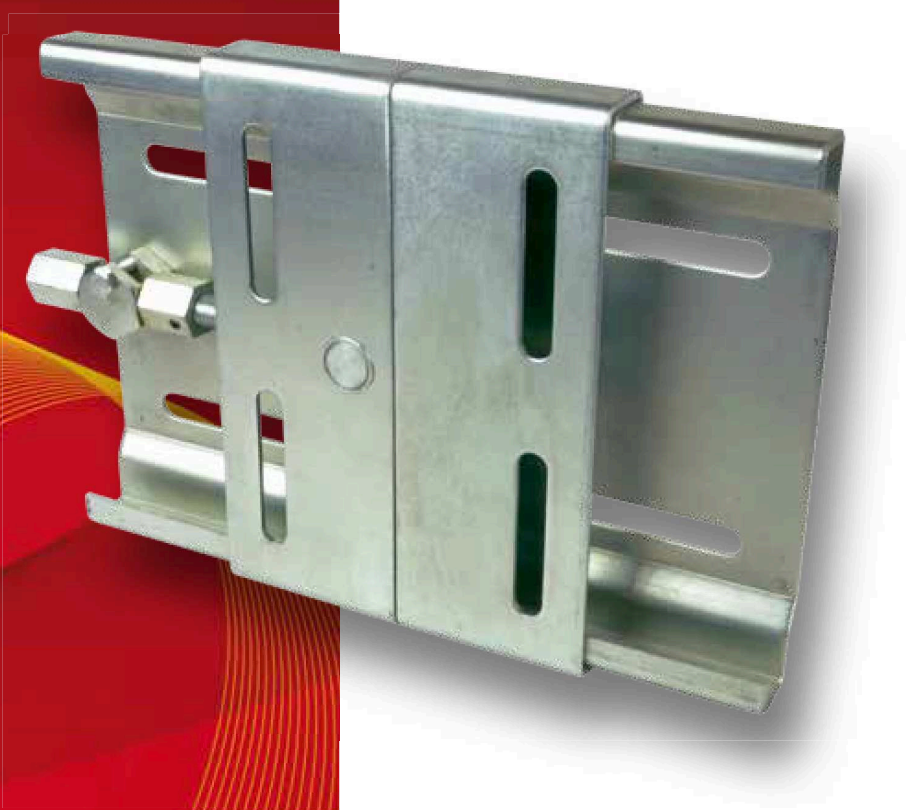

SLITTE TENDICINGHIA

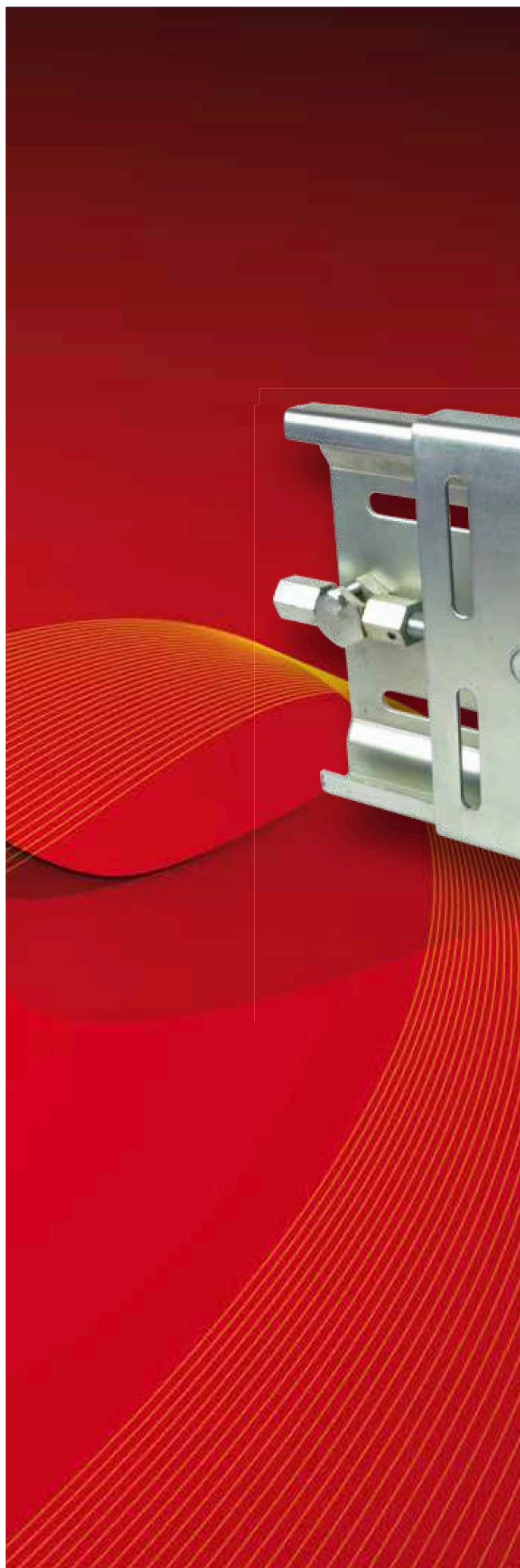





SLITTE TENDICINGHIA PER MOTORI ELETTRICI

3

MATERIALE

Lamiera Zincata FE 430

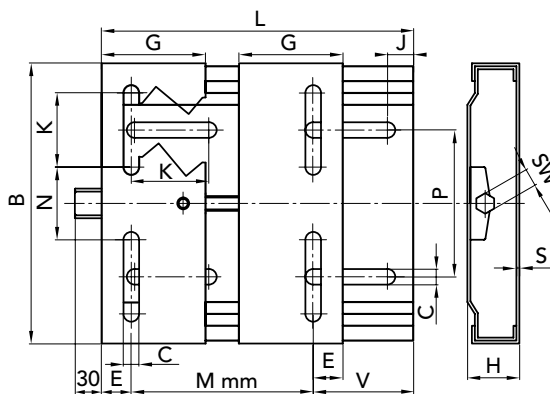

DIMENSIONI

GRAND. MOT.	TIPO	CODICE	L	B	H	Mmin	G	E	J	K	C	N	P	SW	S
63/80	210	90100210	210	195	33	100	70	20	25	50	10,5	43	98	19	3
63/112	270	90100270	270	195	33	100	70	20	25	50	10,5	43	98	19	3
90/132	340	90100340	340	290	40	135	95	27	29	62,5	12,5	90	165	22	4
100/160	430	90100430	430	290	40	140	95	27	29	62,5	12,5	90	165	22	4
160/180	490	90100490	490	410	40	254	95	40	30	60	15	193	284	22	4

AMPIEZZA DI REGOLAZIONE

TIPO	63	71	80	90	100	112	132	160	180	PESO kg
210	70	58	45							2,2
270	130	118	105	90	70	40				2,8
340				140	130	100	75			6,7
430					216	186	160	122		7,5
490								156	131	10,8



Quantità, disponibilità e prezzi con B2B Chiaravalli



IE 1

TIPO	POLI	POTENZA Kw	TENSIONE V	CORRENTE 400 V	COPPIA N/m	RENDIMENTO %	FATTORE COS. Ø	PESO Kg.	
CHT 56	B2	2	0.13	230/400	0.40	0.42	62.00	0.69	3.20
CHT56	B4	4	0.09	230/400	0.43	0.64	50.00	0.61	3.20
CHT63	A2	2	0.18	230/400	0.55	0.63	63.00	0.75	4.00
CHT63	B2	2	0.25	230/400	0.71	0.88	65.00	0.78	4.40
CHT63	C2	2	0.37	230/400	1.05	1.30	65.00	0.78	4.90
CHT63	A4	4	0.12	230/400	0.47	0.85	57.00	0.64	3.90
CHT63	B4	4	0.18	230/400	0.70	1.27	57.00	0.65	4.50
CHT63	C4	4	0.22	230/400	0.92	1.77	59.00	0.67	4.80
CHT63	B6	6	0.12	230/400	0.62	1.27	45.00	0.62	4.80
CHT71	A2	2	0.37	230/400	0.97	1.29	70.00	0.79	5.60
CHT71	B2	2	0.55	230/400	1.42	1.90	71.00	0.79	6.10
CHT71	A4	4	0.25	230/400	0.84	1.77	60.00	0.62	5.60
CHT71	B4	4	0.37	230/400	1.12	2.58	65.00	0.74	6.20
CHT71	C4	4	0.55	230/400	1.61	3.81	66.00	0.75	7.00
CHT71	A6	6	0.18	230/400	0.70	1.95	56.00	0.66	6.00
CHT71	B6	6	0.25	230/400	0.87	2.65	59.00	0.70	6.50
CHT71	C6	6	0.37	230/400	1.27	3.97	61.00	0.69	7.20
CHT80	A4	4	0.55	230/400	1.59	3.81	67.00	0.75	8.90
CHT80	A6	6	0.37	230/400	1.23	3.93	62.00	0.70	8.20
CHT80	B6	6	0.55	230/400	1.65	5.80	67.00	0.72	9.90

IE 2

MOTORI EFFICIENZA IE 2

Dal mese di Giugno 2011, i motori 2 - 4 - 6 poli con potenze comprese tra 0,75 Kw e 375 Kw, commercializzati all'interno dell'Unione europea, dovranno rispondere alla nuova normativa EU MEPS European Union Minimum Energy Performances Standards per quanto riguarda il livello di efficienza, al fine di ridurre i consumi e le emissioni di CO2.

La sigla IE 2 riportata sulla targia dei motori indicherà l'appartenenza a questa categoria.

TIPO	POLI	POTENZA Kw	TENSIONE V	CORRENTE 400 V	COPPIA N/m	RENDIMENTO %	FATTORE COS. Ø	PESO Kg.	
CHT80	A2	2	0.75	230/400	1.75	2.51	77.40	0.80	9.10
CHT80	B2	2	1.10	230/400	2.45	3.69	80.00	0.82	10.70
CHT80	C2	2	1.50	230/400	3.12	4.97	82.70	0.83	13.00
CHT80	B4	4	0.75	230/400	1.79	5.04	79.60	0.76	11.20
CHT80	C4	4	1.10	230/400	2.72	7.39	81.40	0.71	13.50
CHT90	S2	2	1.50	230/400	3.20	4.95	81.40	0.83	13.30
CHT90	L2	2	2.20	230/400	4.54	7.38	83.20	0.84	16.00
CHT90	S4	4	1.10	230/400	2.50	7.37	81.40	0.78	13.90
CHT90	L4	4	1.50	230/400	3.31	10.09	82.80	0.79	16.20
CHT90	M4	4	2.20	230/400	5.09	14.71	84.30	0.74	20.50
CHT90	S6	6	0.75	230/400	2.01	7.66	76.00	0.71	13.0
CHT90	L6	6	1.10	230/400	2.82	11.23	78.10	0.72	16.30
CHT100	LA2	2	3.00	230/400	5.88	10.05	84.60	0.87	23.00
CHT100	LA4	4	2.20	230/400	4.83	14.70	84.30	0.78	22.70
CHT100	LB4	4	3.00	230/400	6.33	20.00	85.50	0.80	26.50
CHT100	LA6	6	1.50	230/400	3.71	15.20	80.00	0.73	22.00
CHT 112	M2	2	4.00	230/400	7.56	13.13	86.00	0.89	27.00
CHT112	M4	4	4.00	230/400	8.23	26.60	86.60	0.81	32.50
CHT112	L4	4	5.50	230/400	11.25	36.57	87.90	0.80	39.00
CHT112	M6	6	2.20	230/400	5.17	22.30	81.80	0.75	29.50
CHT132	SA2	2	5.50	230/400	10.25	18.00	87.20	0.89	40.20
CHT132	SB2	2	7.50	230/400	13.80	24.47	88.10	0.89	45.00
CHT132	S4	4	5.50	230/400	11.00	36.22	87.90	0.83	44.00
CHT132	M4	4	7.50	230/400	14.50	50.00	88.70	0.84	53.50
CHT132	M6	6	4.00	230/400	8.86	40.42	84.60	0.77	45.00
CHT132	S6	6	3.00	230/400	6.84	30.48	83.30	0.76	36.10

* A richiesta motori da 160 a 355

* Volt 400/690 standard da 160 a 355 a richiesta sugli altri

* A richiesta è fornibile motore marca ABB

* A richiesta è fornibile motore autofrenante marca MGM

Disegni CAD disponibili sul sito
www.chiaravalli.com

Quantità, disponibilità e prezzi
con B2B Chiaravalli



B5

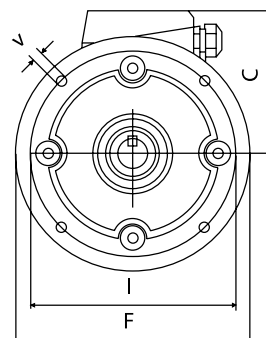
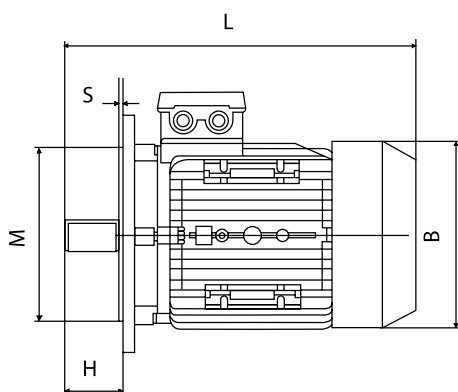
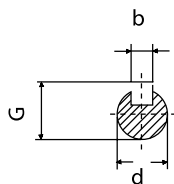

B14

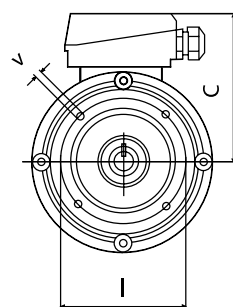
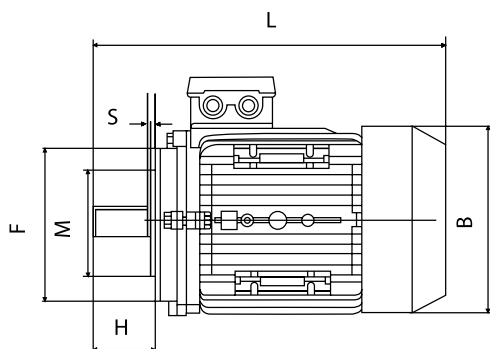
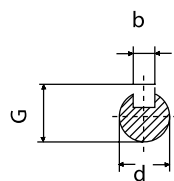

B3

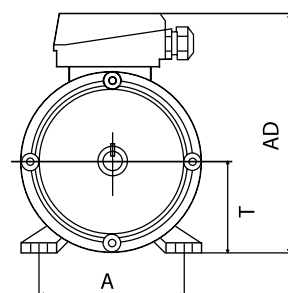
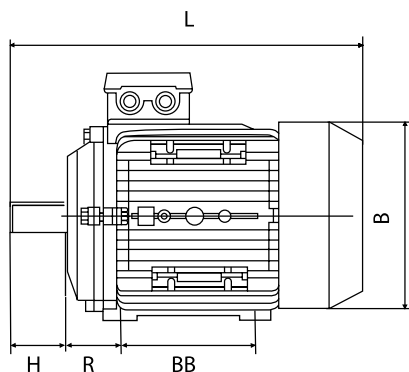
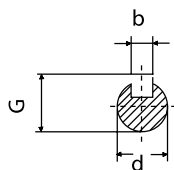

DIMENSIONI DI MONTAGGIO (mm)

TIPO						B5					B14					B3					INGOMBRI		
	d	H	b	G		I	M	F	V	S	I	M	F	V	S	R	BB	A	T	AD	B	C	L
56	9	20	3	10.2		98	80	120	7	3.0	65	50	80	M5	2.5	36	71	90	56	156	110	100	195
63	11	23	4	12.5		115	95	140	10	3.0	75	60	90	M5	2.5	40	80	100	63	173	123	110	215
71	14	30	5	16		130	110	160	10	3.5	85	70	105	M6	2.5	45	90	112	71	188	138	117	255
80	19	40	6	21.5		165	130	200	12	3.5	100	80	120	M6	3.0	50	100	125	80	217	155	137	290
90S	24	50	8	27		165	130	200	12	3.5	115	95	140	M8	3.0	56	100	140	90	235	176	145	310
90L/90LL	24	50	8	27		165	130	200	12	3.5	115	95	140	M8	3.0	56	125	140	90	235	176	145	335
100L	28	60	8	31		215	180	250	15	4.0	130	110	160	M8	3.5	63	140	160	100	252	197	152	386
112M	28	60	8	31		215	180	250	15	4.0	130	110	160	M8	3.5	70	140	190	112	292	220	180	395
132S	38	80	10	41		265	230	300	15	4.0	165	130	200	M10	4.0	89	140	216	132	325	257	195	436
132M	38	80	10	41		265	230	300	15	4.0	165	130	200	M10	4.0	89	178	216	132	325	257	195	475